

General Information

Type Selection

How to order

Installation Instruction

PSI Sealing Plugs

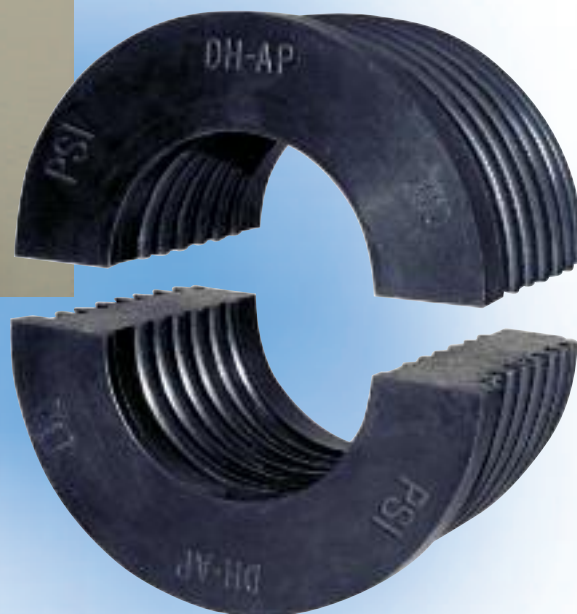

Pipeline Accessories

PSI-Sealing Plugs

General Information



Product description

The PSI plug is a sealing device consisting of two half shells. It is especially designed to seal cables and pipes passing through walls and ceilings. Due to the large variety of sizes and rubber types, you can use this sealing plug for almost any pipe or cable. The installation is fast and simple and can be done without the use of special tools as the plug is just hammered in the annular space. The profiled design of the plug makes installation easy and ensures a

pressure tightness up to 3 bar. The relevant test certificates are available. All PSI plugs are manufactured from high quality rubber and are highly resistant to abrasion. We can supply plugs with five different rubber types to ensure suitability for all industry sectors, such as construction, marine, power and offshore.

Advantages

- pressure tight up to 3 bar
- easy installation
- large range of application
- noise absorbing
- fire retarding qualities
- vibration absorbing
- no electrical conduit
- high resistance to abrasion
- can be installed horizontally and vertically
- several rubber qualities with chemical resistance

Certificates		
Application	Certified by	Value
Pressure	Lloyd's 	3 bar
Fire/Construction	Warrington	1 hour
Fire / Marine	IMO Regulations - Lloyd's certified 	1 hour

PSI-Sealing Plugs

Application Range



Sealing a wall opening

The plug can be used in a core drilled hole if the surface is in a good shape. The plug is hammered in the annular space from the outside of the wall. A pressure tightness of 3 bar can be achieved. The plug can also be used in wall sleeves of different materials (PVC, ASTM, DIN ...)

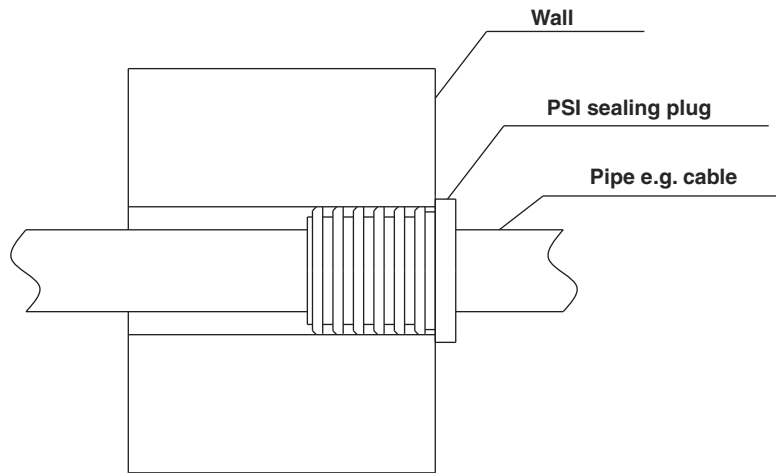

Application in ship building industry

The plugs are installed from both sides in a welded sleeve situated in a wall or deck. In these cases you will use the high fire retardant rubber FS.

Fire resistance of 60 minutes was tested and certified according to the IMO Fire Test Procedure Code Annex 1, part. 3. The welded in sleeve will then be wrapped with Rockwool.

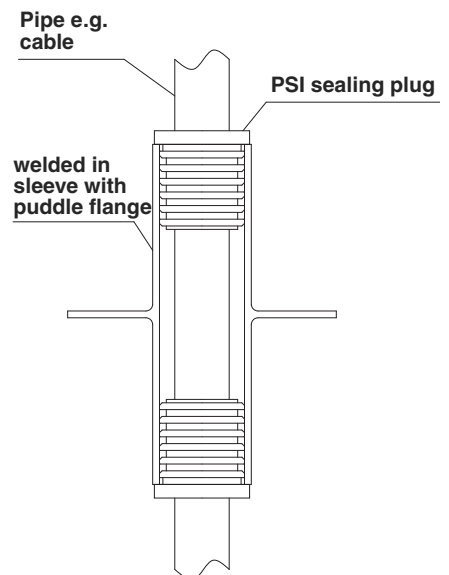
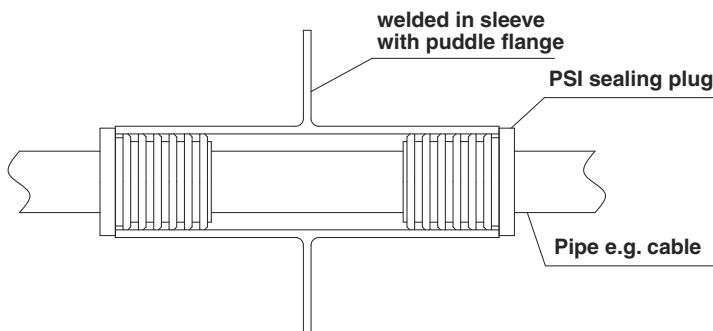

Use in yacht building

In the case of materials which cannot be welded, e.g. glass fibre reinforced plastics, the sleeve is screw-mounted to

a wall or the deck with the flange and a thrust washer. The sealing plug can then be driven in without difficulty.

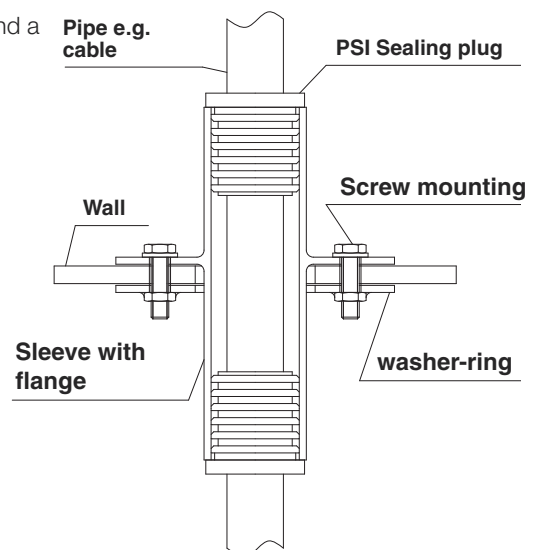
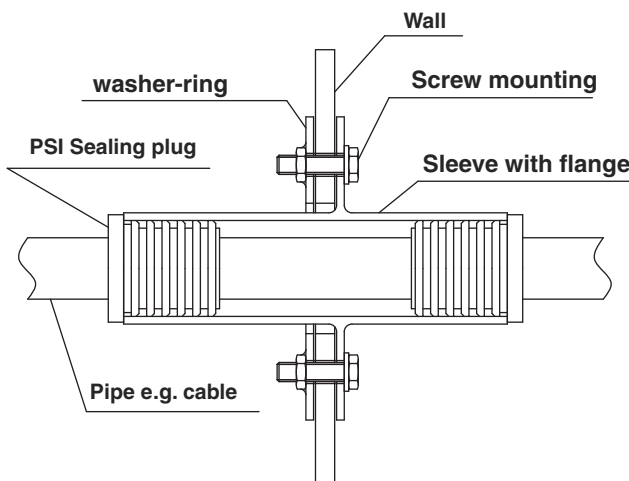

Selection of types and rubber quality



Outer dia. range Ø (mm)	Duct dia. range Ø (mm)
25.6	5-11
33.6	5-20
35	5-15
37.2	5-18
40	5-22
43.6	5-28
50	5-32
52.5	15-30
54.5	15-34
57,3	25 / 32
60	20-40
68.6	20-50
70	22-50
77.9	20-50
80	30-56
82.5	30-60
90	30-62
94	32 / 40 / 50
100	30-64
102.3	30-70

Outer dia. range Ø (mm)	Duct dia. range Ø (mm)
103.6	30-74
107.1	50-82
110	62 / 74
118.6	28 / 46 / 52
118.6	60-94
125	40-90
128.1	50-94
131.7	70-100
150	60-124
152	86-124
154.1	60-120
159.3	80-124
160	90 / 110 / 124
190.2	124-152
200	100-160
202.7	80-160
207.3	122-162
237.6	150-182
250	150-200
254.4	100-200
260.4	150-200

Rubber quality

	Material	Colour	temperature range	Characteristics
	EPDM (001)	black	-25°C/+110°C	standard rubber for gas and water tight sealings
	Nitrile (003)	blue	-25°C/+110°C	restistant to hydrocarbons and greases
	FS (002)	red	-30°C/+120°C	highly fire retarding rubber
	Silicone (004)	brown	-60°C/+200°C	for high/low temperatures
	Viton (005)	green	-25°C/+200°C	high resistance against chemicals



PSI-Sealing Plugs

How to find the right type

5 steps to find the right PSI Plug

1. Find out which kind of wall opening you have

The cable/pipe will be passed through which sleeve or core drilled hole?

- PVC-Sleeve
- Core drilled hole / Aluminium sleeve (DH-AP)
- DIN Steel sleeve
- ASTM steel sleeve

2. Determine the I.D of the opening

It is very important to check the exact I.D. of the opening as this corresponds to the O.D. of the PSI Sealing Plug. Example: PVC Sleeve diam. 110 mm with a wall thickness of 3.2 mm. The I.D. will be 103.6 mm. This is also the O.D. of the correct Sealing Plug.

3. Determine the O.D. of the cable or pipe

The O.D. of the cable or pipe corresponds to the I.D. of the Sealing Plug. The diameter can be rounded down to whole millimeters. For example 20.6 mm = 20 mm. By doing this you ensure a safe and correct sealing. The PSI Sealing Plug systems shows a minimum to maximum opening range per diameter. This range shows the smallest possible pipe/cable and the largest one. For the serial 103.6 mm the smallest is 30 mm and the largest is 74 mm.

4. Which rubber is the right one?

The PSI Sealing Plug is available in 5 rubber qualities. EPDM for standard applications in the gas and water, Viton for chemical resistance etc.

5. Summary

The description of the PSI Sealing Plug consists of 3 elements:

1. I.D. of the core drilled hole or sleeve = Dimension indicated on the plug
2. O.D. of the cable or pipe
3. Rubber quality

Example: You have a pipe with an O.D. of 50 mm and a PVC sleeve (diam. 110 mm). The sealing shall be gas and water tight: 103.6/50 EPDM.

Installation instruction



1. Preparation of the wall opening

The wall opening (PVC sleeve, core drilled hole, steel sleeves....) must be cleaned inside. Please make sure that there is no dirt.

2. Greasing

Grease the inside of the wall opening and the outside and inside of the sealing plug with acid free Vaseline. This makes installation much easier and ensures a longer sealing life. You can get the Vaseline from PSI (150 ml).

3. Installation

Please make sure that the cable or pipe is laying straight and centred in the wall opening. Put the two half shells of the PSI Sealing Plug around the cable or pipe and push the sealing in the opening. Attention: both half shells must be correctly positioned on each other. The plug must be pushed in until the flange touches the wall. Don't push any further !!

If installation is more difficult (for example with larger plugs) use a piece of wood and a hammer and carefully push in the sealing.

Please consider:

- Plug can be disassembled only from the backside
- Tolerance OD max. +1mm
- Plug is not recompressable
- Weight of the pipe has to be carried/bearred otherwise

